

# Faria®

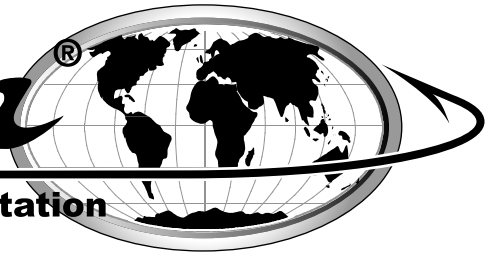

**World Class Instrumentation**



## Owner's Manual

# MANUAL ENGINE CONTROL MODULE 701HC & 701HC-NK

**ISO225**

ISO201A ECR/#5455 6/05

# Specifications

## DC Supply:

8 to 35 V Continuous.

## Cranking Dropouts:

Able to survive voltage dips during cranking.  
*This is achieved without the need for internal batteries.*

## Alternator Input Range:

15 - 305 V AC RMS (+20%)

## Alternator Input Frequency:

50 - 60 Hz at rated engine speed.

(Minimum 75V AC)

Overspeed: nominal frequency +14% (+24% Overshoot)

## Start Output:

Solid State 1.2A negative grounding terminal

## Run Output:

Solid State 1.2A negative grounding terminal

## Pre-heat Output:

Solid State 1.2A negative grounding terminal

## Dimensions:

84mm X 72mm X 34.9mm

(3.30" x 2.83" x 1.49") (Excluding Key-switch)

Cut-out 80mm x 68mm (3.14" x 2.67")

## Operating Temperature Range:

-30 to +70°C

## Installation:

Front panel mounting through cut-out.  
Retaining clips supplied. Wire connections via screw clamp type terminals

## Calibration:

Speed trip setting switch accessible from rear of module.

Specifications may change without notice.

## Case Dimensions (MM)

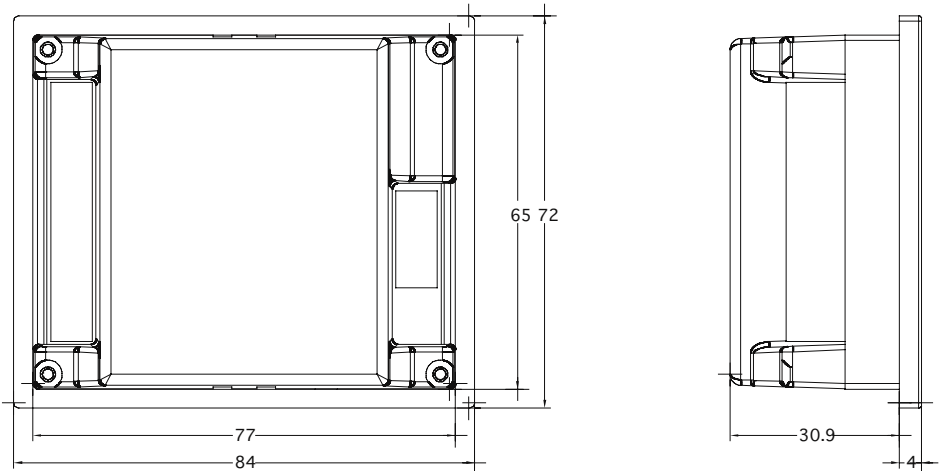

Overall dimensions

3.3" x 2.8" x 1.4"

(protrudes 0.16" out of panel)

Panel cutout 3.0" x 2.6"

Imperial measurements

72mm = 2.83"

65mm = 2.55"

30.9mm = 1.21"

4.0mm = 0.15"

77mm = 3.03"

84mm = 3.30"

Panel Cut-out

68mm = 2.67"

80mm = 3.14"

# 701HC





## Description

The Model 701HC is a **Manual Engine Control Module** designed to control the engine via a key switch and push buttons on the front panel. The module is used to start and stop the engine and indicate fault conditions, automatically shutting down the engine and indicating the engine failure by LED, giving true, first fault annunciation. An integral anti-tamper LCD hourmeter is also provided.

## Operation



of the module 701HC (with Key):

1. Select manual run (  ) turn key.
2. Depress pre-heat button (  ) for required length of time. Operation of the pre-heat button is only possible when the module is enabled.
3. Press START (  ) to crank engine

When key is in the 'O' position the DC supply is removed from the module and the run output is de-energised.

The module is powered up when the key is in the  position. Operation of the pre-heat button is only possible when the key is in this position.



An LED tell-tale indicates pre-heat operation. Once the required pre-heat duration has elapsed, the pre-heat button (  ) should be released.

Once  is selected and the Start button is pressed and maintained, the engine fuel system is energised. The 'Crank' output is then energised and the starter motor operated, disengaging automatically when the engine fires or when the 'Start' (  ) button is released. The protection hold-off timer (10 seconds) is then initiated.

After the starter motor has disengaged, the **Safety On** timer is activated (which is fixed at 12 seconds), allowing Oil Pressure, High Engine Temp., and Charge Fail to stabilize without triggering a fault.

**▲ Note:** The protection hold-off timer is pre set to 10 seconds (  ) and can not be changed.

**▲ Note:** If the generator has not started when the start (  ) button has been released or the generator fails once it is running, the external key switch must be disabled and then enabled before another start can be invoked.

**▲ Note:** If pre-heat is required during cranking, the pre-heat (  ) button should be pressed at the same time as the start (  ) button.

**▲ Note:** The 701HC start button is represented by (  )

Any of the following alarms (which close on fault and switch to ground) will cause the run output to de-energise:

- **Low Oil Pressure**
- **High Engine Temperature**
- **Auxiliary Shutdown**
- **Overspeed**

This will remove the fuel supply from the engine and bring it to rest.

Each alarm has its own LED indicator and once activated no further alarm conditions will be accepted. The alarm output and relevant LED will remain active until the unit is reset by turning the switch to the 'O' position.

**Low Oil Pressure**, if the module detects that the engine oil pressure has fallen below the low oil pressure switch setting after the Safety On timer has expired, a shutdown will occur.

The  icon will illuminate.

**High Engine Temperature**, if the module detects that the engine coolant temperature has exceeded the high engine temperature switch setting, after the Safety On timer has expired, a shutdown will occur.

The  icon will illuminate.

**Auxiliary input**, If the auxiliary input is energised an immediate shutdown will occur.

The  icon will illuminate.

### Overspeed Protection

Overspeed protection is derived from the generator Hz output. The over frequency circuit monitors the generator Hz output and will shut down the engine immediately if a pre-set frequency level is exceeded. This trip level is selected by a switch for either 50Hz or 60Hz nominal operation (57Hz and 68Hz trip respectively)

During engine cranking and for a short time afterwards the **protection hold-off timer** (10 seconds) is active and the relevant alarm inputs are inhibited. This enables the engine to start and achieve normal running conditions. Once the timer has expired the inputs are enabled providing normal protection from the module.

The  icon will illuminate.

 **Note:** During the start-up sequence the overspeed trip level is extended to 24% above the normal frequency for the duration of the safety timer to allow an extra trip level margin. This is used to prevent nuisance tripping on start-up.

 **Note:** The protection hold-off timer is preset to 10 seconds and can not be changed.

**Charge Failure warning** is also provided by monitoring the WL (warning light) terminal on the charge alternator.

If no voltage is detected from the warning light terminal on the auxiliary charge alternator, the  icon will illuminate.

 **Note:** If the Auxiliary input is used to shutdown the engine, the fault must be cleared before the unit can be reset and the engine restarted.

**LCD Hourmeter** is advanced incrementally whenever the engine is running. The elapsed hours are displayed when the module is enabled.

## Configuration Instructions:

- The only parameter to be configured is the nominal frequency, either 50 Hz or 60 Hz. The change is made via a switch which is accessible through a slot in the base of the module.

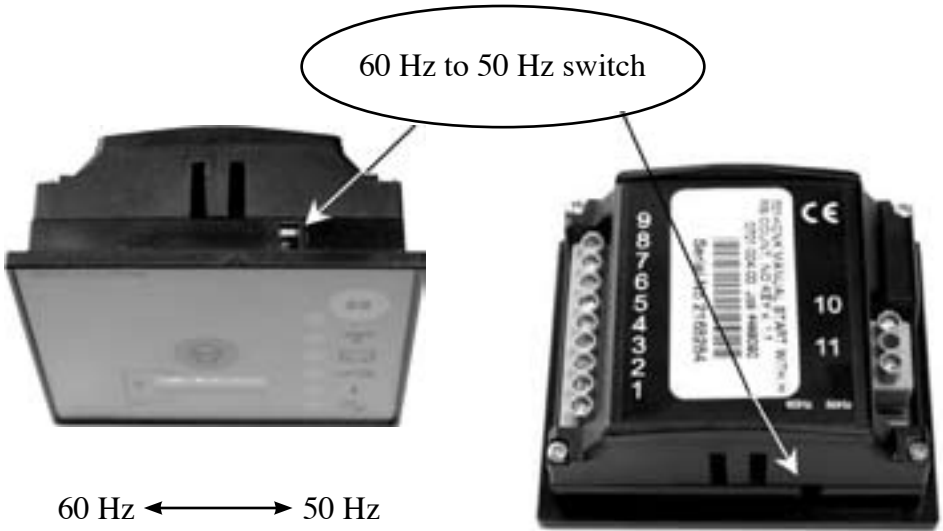

- The switch adjusts the over speed trip from 57 Hz to 68 Hz, and over shoot from 62 Hz to 70 Hz.

# Typical Connections 701HC

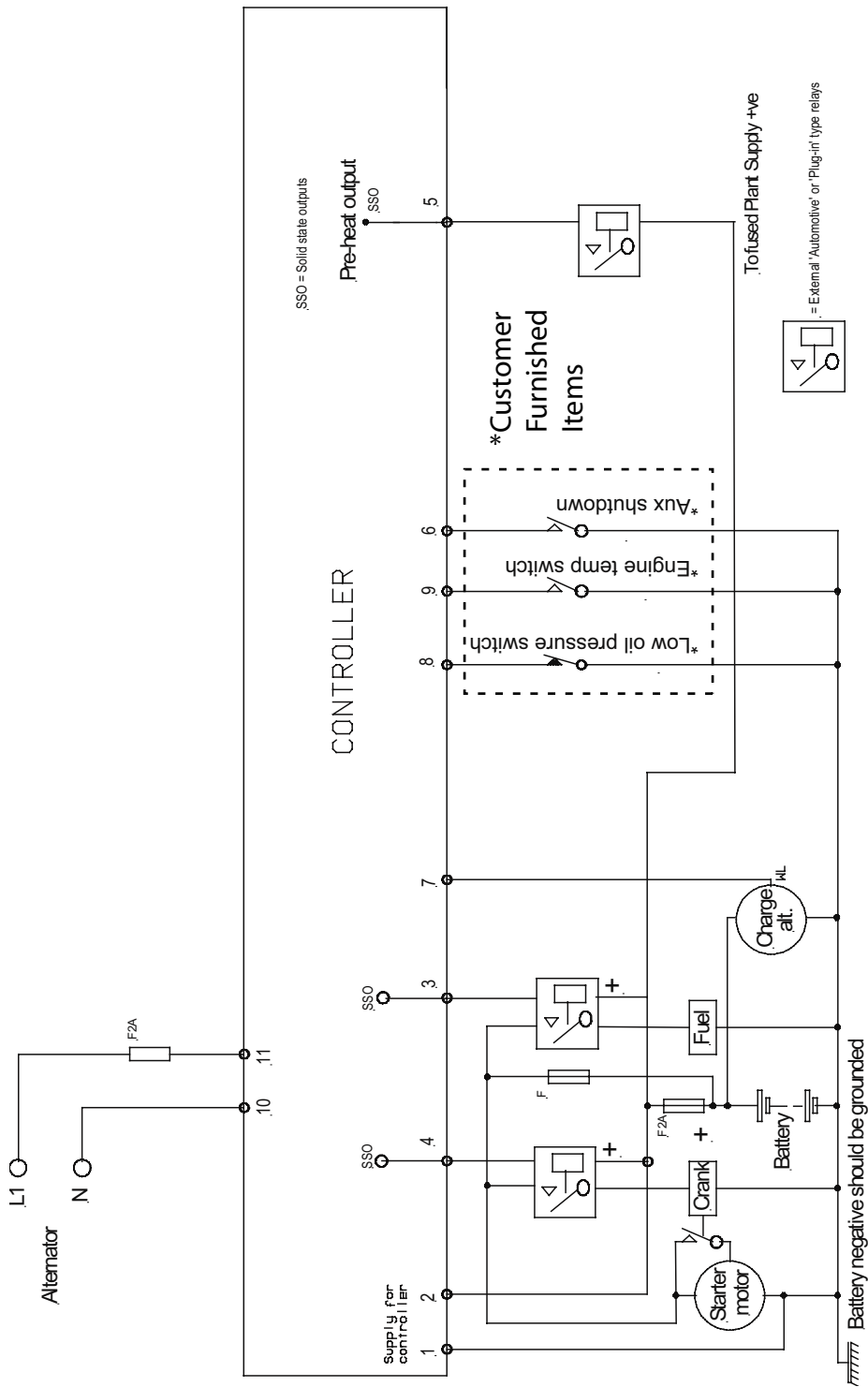

# 701HC-NK





## Description

The Model 701HC-NK is a **Manual Engine Control Module** designed to control the engine via push buttons on the front panel. The module is used to start and stop the engine and indicate fault conditions, automatically shutting down the engine and indicating the engine failure by LED, giving true first fault annunciation. An integral anti-tamper LCD hourmeter is also provided.

## Operation

of the module 701HC-NK (No Key):

1. Enable the module by applying DC power to the module (usually by turning an external keyswitch)
2. Press pre-heat button  for required length of time. Operation of the pre-heat button is only possible when the module is enabled.
3. Press START  to crank engine.



When the module is disabled the run output is de-energised.



Operation of the pre-heat button is only possible when the module is enabled.



An LED telltale indicates pre-heat operation. Once the required pre-heat duration has elapsed, the pre-heat button should be released.



Once enabled and the Start button pressed and maintained, the engine fuel system is energised. The 'Crank' output is then energised and the starter motor operated, disengaging automatically when the engine fires or when the 'Start' button is released. The protection hold-off timer (10 seconds) is then initiated.

After the starter motor has disengaged, the **Safety On** timer is activated (which is fixed at 12 seconds), allowing Oil Pressure, High Engine Temp., and Charge Fail to stabilize without triggering a fault.

 **Note:** The protection hold-off timer is pre set to 10 seconds  and can not be changed.

 **Note:** If the generator has not started when the start  button has been released or the generator fails once it is running, the external key switch must be disabled and then enabled before another start can be invoked.

 **Note:** If pre-heat is required during cranking, the pre-heat  button should be pressed at the same time as the start  button.

 **Note:** The 701HC-NK start button is represented by 

Any of the following alarms (which close on fault and switch to ground) will cause the run output to de-energise:

- **Low Oil Pressure**
- **High Engine Temperature**
- **Auxiliary Shutdown**
- **Overspeed**

This will remove the fuel supply from the engine and bring it to rest.

Each alarm has its own LED indicator and once activated no further alarm conditions will be accepted. The alarm output and relevant LED will remain active until the unit is reset by disabling the module (usually by turning an external keyswitch).

**Low Oil Pressure**, if the module detects that the engine oil pressure has fallen below the low oil pressure switch setting after the Safety On timer has expired, a shutdown will occur.

The  icon will illuminate.

**High Engine Temperature**, if the module detects that the engine coolant temperature has exceeded the high engine temperature switch setting, after the Safety On timer has expired, a shutdown will occur.

The  icon will illuminate.

**Auxiliary input**, If the auxiliary input is energised an immediate shutdown will occur.

The  icon will illuminate.

### Overspeed Protection

Overspeed protection is derived from the generator Hz output. The over frequency circuit monitors the generator Hz output and will shut down the engine immediately if a pre-set frequency level is exceeded. This trip level is selected by a switch for either 50Hz or 60Hz nominal operation (57Hz and 68Hz trip respectively)

During engine cranking and for a short time afterwards the **protection hold-off timer** (10 seconds) is active and the relevant alarm inputs are inhibited. This enables the engine to start and achieve normal running conditions. Once the timer has expired the inputs are enabled providing normal protection from the

module.

The  icon will illuminate.

 **Note:** During the start-up sequence the overspeed trip level is extended to 24% above the normal frequency for the duration of the safety timer to allow an extra trip level margin. This is used to prevent nuisance tripping on start-up.

 **Note:** The protection hold-off timer is preset to 10 seconds and can not be changed.

**Charge Failure warning** is also provided by monitoring the WL (warning light) terminal on the charge alternator.

If no voltage is detected from the warning light terminal on the auxiliary charge alternator, the  icon will illuminate.

 **Note:** If the Auxiliary input is used to shutdown the engine, the fault must be cleared before the unit can be reset and the engine restarted.

**LCD Hourmeter** is advanced incrementally whenever the engine is running. The elapsed hours are displayed when the module is enabled.

### Configuration Instructions.

- The only parameter to be configured is the nominal frequency, either 50 Hz or 60 Hz. The change is made via a switch which is accessible through a slot in the base of the module.
- The switch adjusts the over speed trip from 57 Hz to 68 Hz, and over shoot from 62 Hz to 70 Hz.  
(See configuration instructions in 701HC instructions)



# Typical Connections 701HC-NK

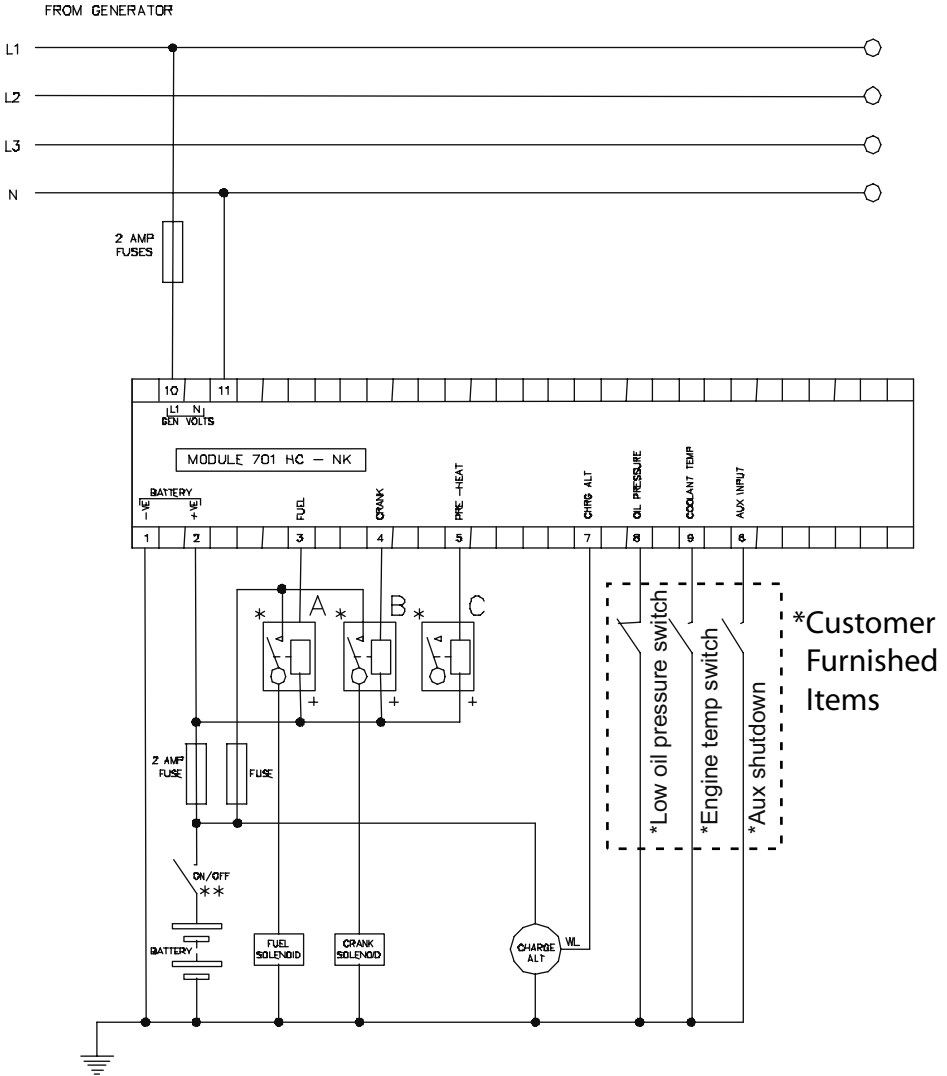

\*Customer  
Furnished  
Items

BATTERY NEGATIVE MUST BE GROUNDED

TERMINALS SUITABLE FOR 22-16 AWG ( $0.6\text{mm}^2$  -  $1.3\text{mm}^2$ ) FIELD WIRING

TIGHTENING TORQUE =  $0.8\text{Nm}$  (7lb-in)

\* NOTE. ALL THE OUTPUTS ARE SOLID STATE AND ARE NEGATIVE SWITCHING

\*\* NOTE. THIS SWITCH MUST BE CAPABLE OF SWITCHING THE TOTAL LOAD OPERATED BY RELAYS A,B AND C

**Notes:**



