

Application	Faria™ 5 Gauge Set*			Publication No. PII53606A
	Description	Part Number	Honda Code	
Outboards	White faced, flat lens	06300-ZW5-010ZB	6315410	<b>Issue Date</b> October 2005
	Black faced, flat lens	06300-ZW5-010ZA	6315402	

\* The water pressure gauge and analog hour meter are not included in the 5 gauge set. They should be ordered separately.

**FOLLOW THESE INSTRUCTIONS CAREFULLY**

- Proper assembly and installation is essential for safe, reliable operation.
- Wear protective gloves when handling parts with sharp edges.

**KIT PARTS LIST**

Remove all kit parts from the box, and check all parts against the following list.

Description	Part Number	Honda Code
Water Pressure Gauge (white face, flat lens)	38351-ZW5-000ZB	6831473
Water Pressure Gauge (black face, flat lens)	38351-ZW5-000ZA	6831481
Analog Hour Meter (white face, flat lens)	39700-ZW5-000ZB	6077788
Analog Hour Meter (black face, flat lens)	39700-ZW5-000ZA	5977780

Use the Faria instrument harness (P/N 32103-ZW7-010AH) to connect Faria gauges to the Honda main harness (refer to page 5 of 14).

**Speedometer**

Ref	Qty	Description
1	1	Speedometer
2	1	Mounting Bracket
3	1	Rubber Hose
4	2	Female Connector
5	2	Brass Nut
6	2	Split Washer
7	1	Red Lens
8	2	Cable Tie

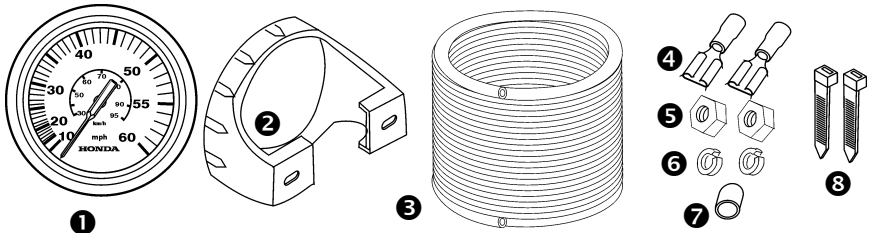

**Tachometer/Hour Meter**

Ref	Qty	Description
1	1	Tachometer
2	1	Mounting Bracket
3	7	Brass Nut
4	5	Split Washer
5	1	Red Lens

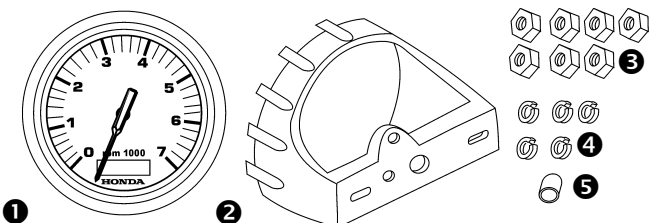

## Fuel Gauge

Ref	Qty	Description
1	1	Fuel Gauge
2	1	Mounting Bracket
3	6	Brass Nut
4	3	Split Washer
5	1	Red Lens

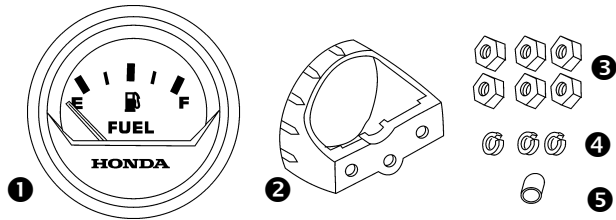

## Trim Meter

Ref	Qty	Description
1	1	Trim Meter
2	1	Mounting Bracket
3	4	Brass Nut
4	2	Split Washer
5	1	Red Lens

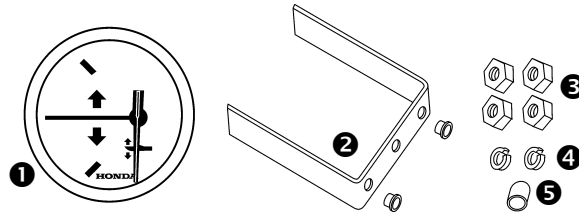

## Volt Meter

Ref	Qty	Description
1	1	Volt Meter
2	1	Mounting Bracket
3	4	Brass Nut
4	2	Split Washer
5	1	Red Lens

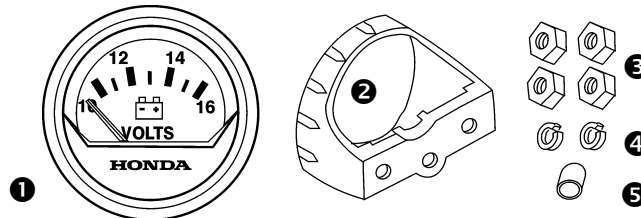

## Water Pressure Gauge (not included in the 5 gauge set)

Ref	Qty.	Description
1	1	Water Pressure Gauge
2	1	Mounting Bracket
3	1	Rubber Hose
4	2	Brass Nut
5	2	Split Washer
6	1	1/8" NPT Fitting
7	1	Red Lens
8	2	Cable Tie
9	1	Adaptor 1/8" NPTF To BSPT

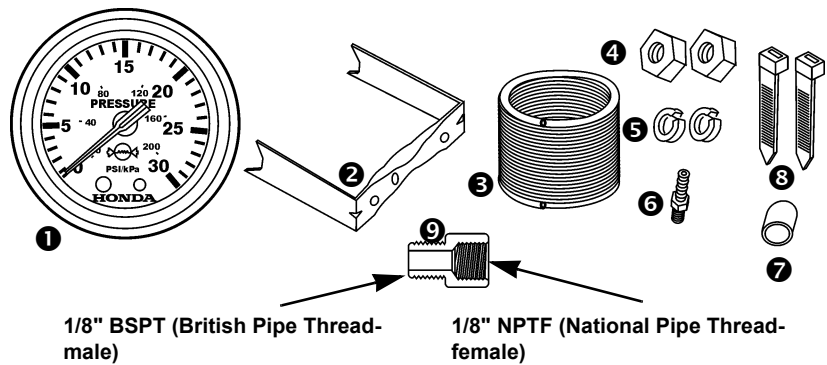

## Analog Hour Meter (not included in the 5 gauge set)

Ref	Qty	Description
1	1	Analog Hour Meter
2	1	Mounting Bracket
3	2	Split Washer
4	2	Brass Nut
5	1	Red Lens

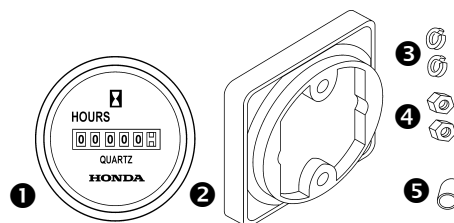

Use the Faria Instrument Harness (P/N 32103-ZW7-000AH) to connect Faria gauges to the Honda main harness (refer to page 5 of 14).

## INSTALLATION

1. Disconnect the negative battery terminal.
2. Select a mounting location for the appropriate gauge(s) that provides easy readability from the operator's position. Check behind each mounting hole location for sufficient installation clearance.
3. Cut a hole in the dash for each gauge to the specification shown.
4. Install the gauge in its mounting hole and check the fit.  
If necessary, install the red lens over the light bulb before installing the gauges:
  - a. Twist the black socket assembly one-eighth turn counterclockwise and remove it.
  - b. Pull the bulb straight out of the assembly.
  - c. Slip the red lens over the bulb and install the socket assembly.
4. Mount the gauges with mounting brackets, split washers, and brass nuts as shown starting on the next page. Tighten the nuts until the gauge can no longer be rotated in the dash.

GAUGE	HOLE DIA.
Speedometer	3-3/8"
Tachometer	3-3/8"
Trim Meter	2-1/16"
Volt Meter	2-1/16"
Fuel Gauge	2-1/16"
Water Pressure	2-1/16"
Hour Meter	2-1/16"

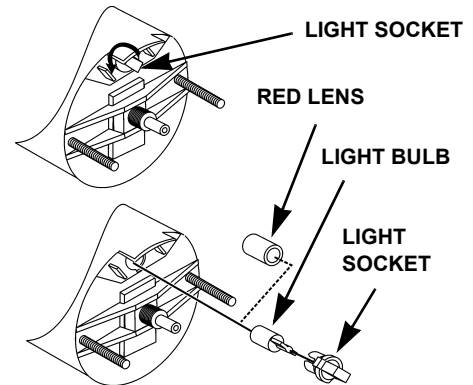

### NOTICE

*Do not overtighten the mounting nuts. Overtightening the nuts may crack the gauge housing, mounting bracket, or mounting panel.*

## GUAGE INSTALLATION

### Speedometer

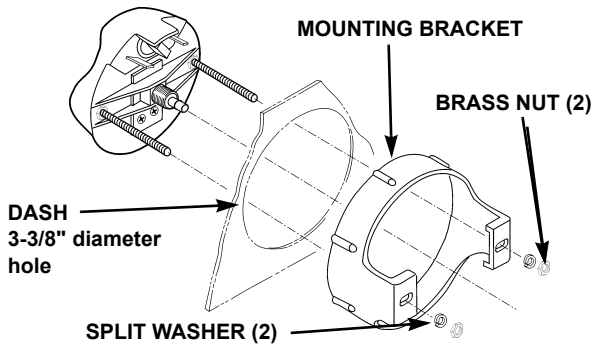

### Fuel Gauge

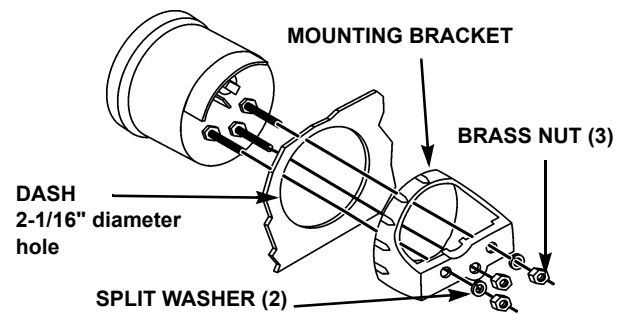

### Tachometer

SELECTOR SWITCH (see below)

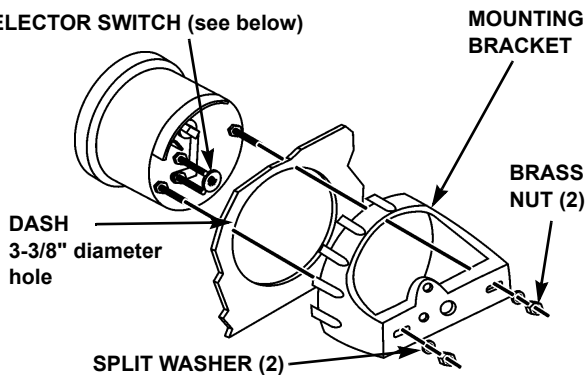

### Water Pressure Gauge

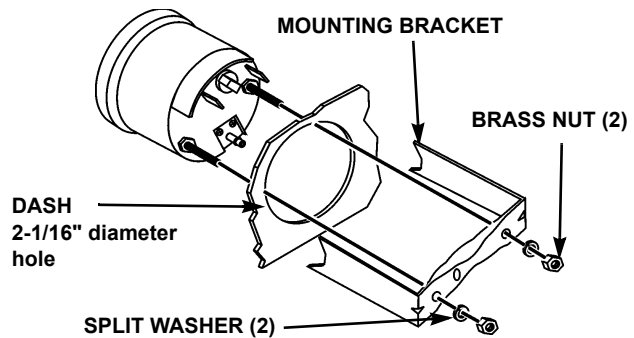

### Trim Meter

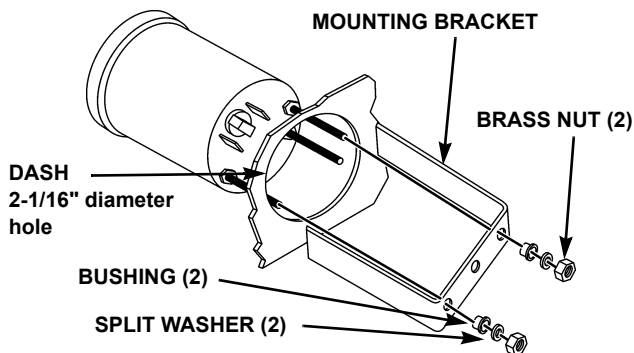

### Hour Meter

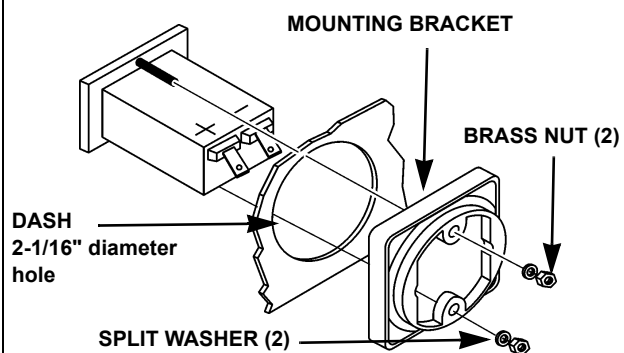

### Volt Meter

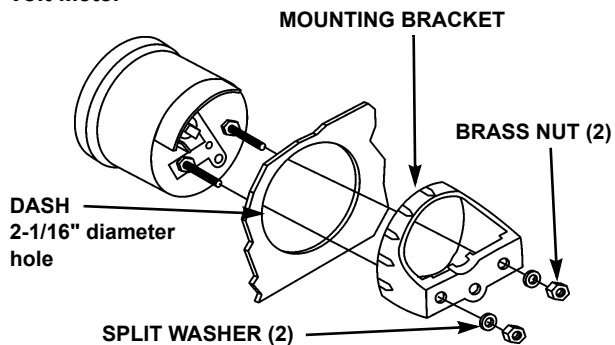

### Tachometer Selector Switch Setting:

Using a small screwdriver, SLIGHTLY depress and turn the selector switch to the desired setting.

Model	Pole	Pulse	Setting
BF8D/9.9D 15D/20D	12	6	4
BF35/45 BF40/50*	6	3	2
BF25/30 BF40/50† BF75/90 BF115/130 BF135/150 BF200/225	4	2	1

\* BF40/50 - 2005 and previous

† BF40/50 - 2006 and subsequent

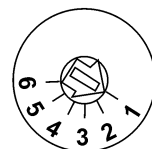

## ELECTRICAL CONNECTIONS

1. Disconnect the battery.
2. Connect the Faria instrument harness to the Honda key switch panel or side mount remote control harness as shown.

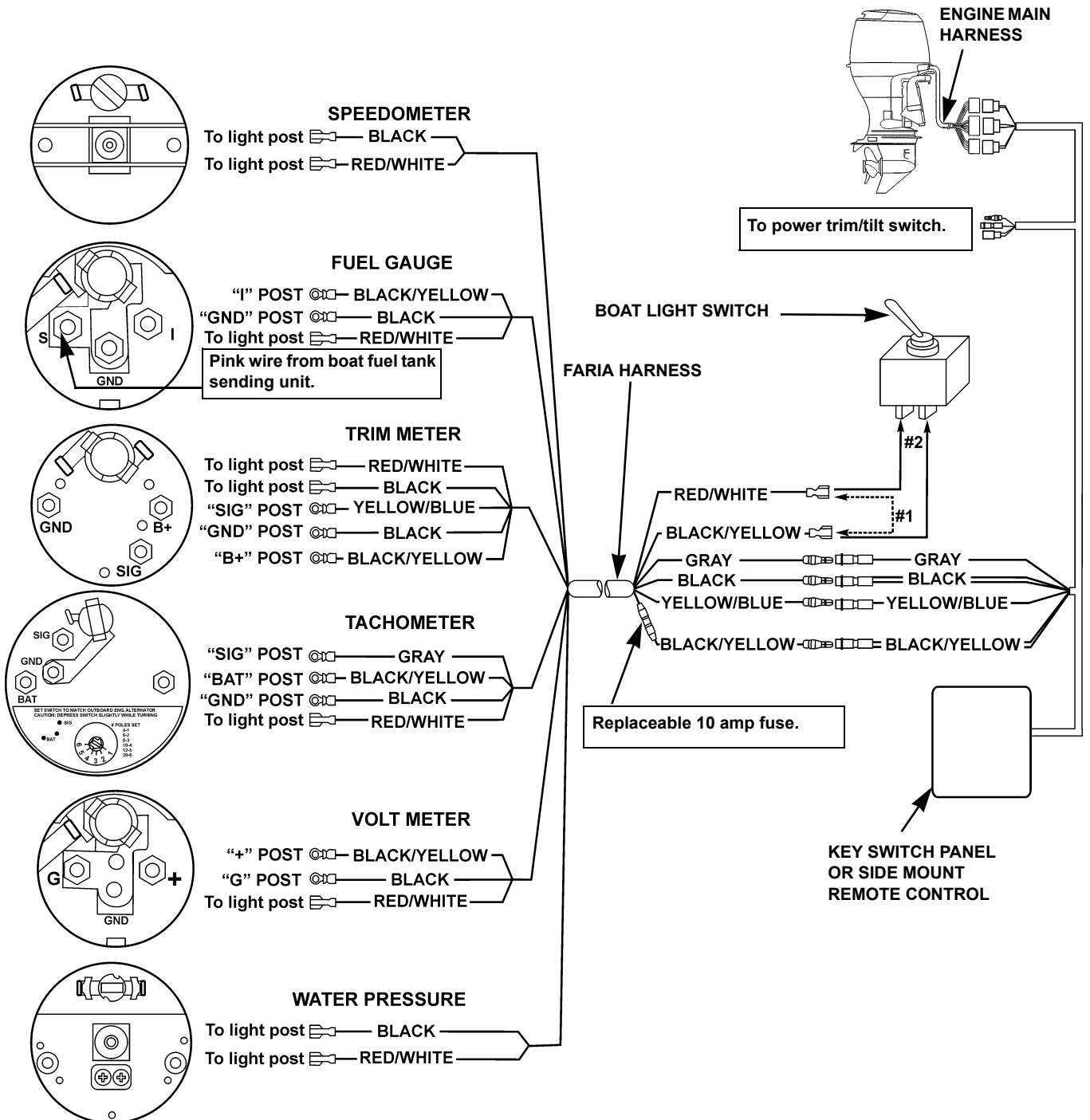

3. Connect the instrument lighting as shown using the instructions below.

#1	Instrument lights operate when Honda key switch is ON.	Connect red/white wire to the black/yellow wire.
#2	Instrument lights operate when boat light switch is ON.	Connect red/white wire and black/yellow wires to the boat light switch.

4. Connect the Faria instrument harness end to the instruments as shown.  
The instrument harness terminal ends are covered for insulation purposes. Remove the covering only on the terminal ends used for gauges that are installed. Leave the covering on unused terminal ends.
5. Secure the wire terminals with the hardware as shown.

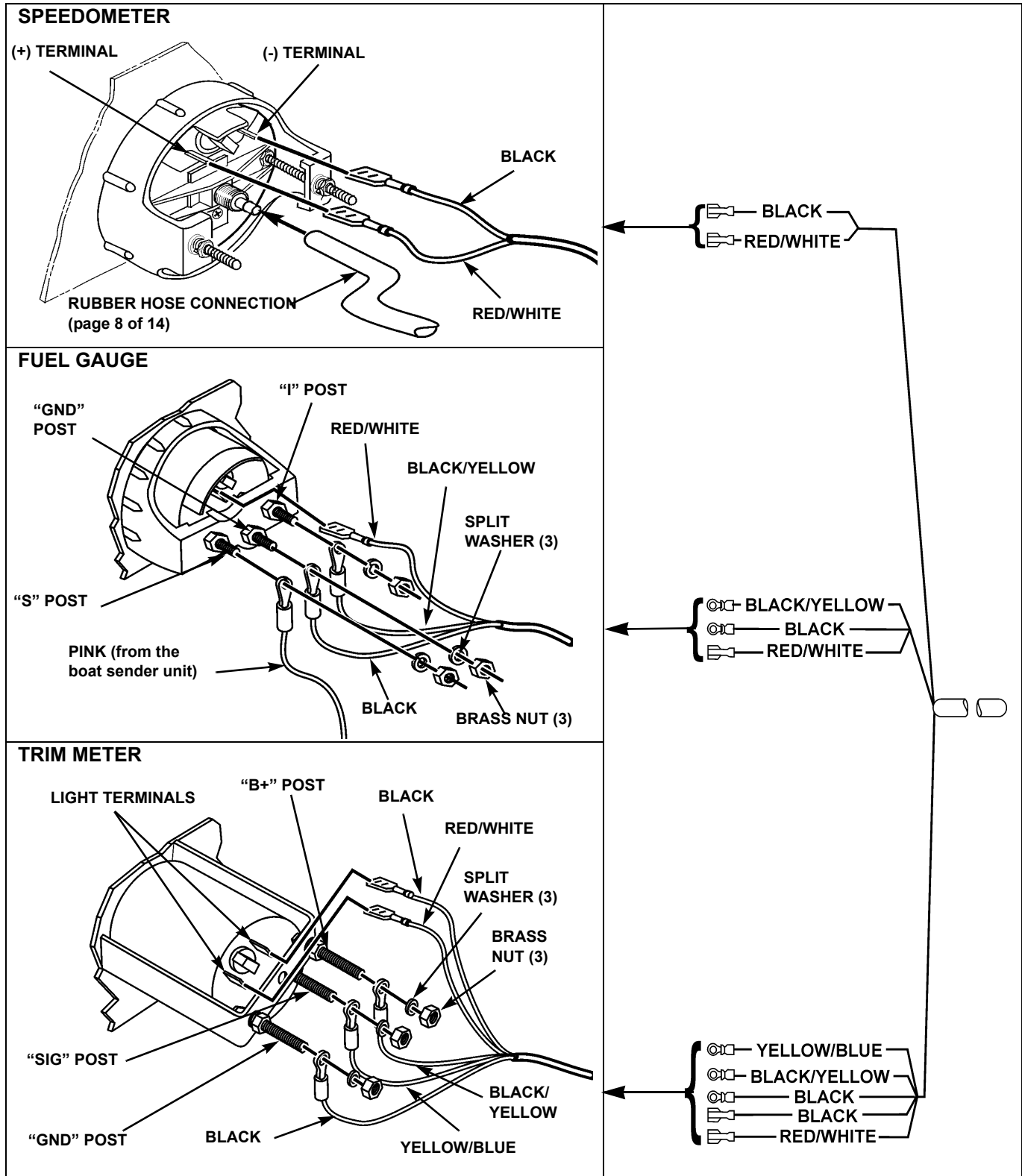

## TACHOMETER

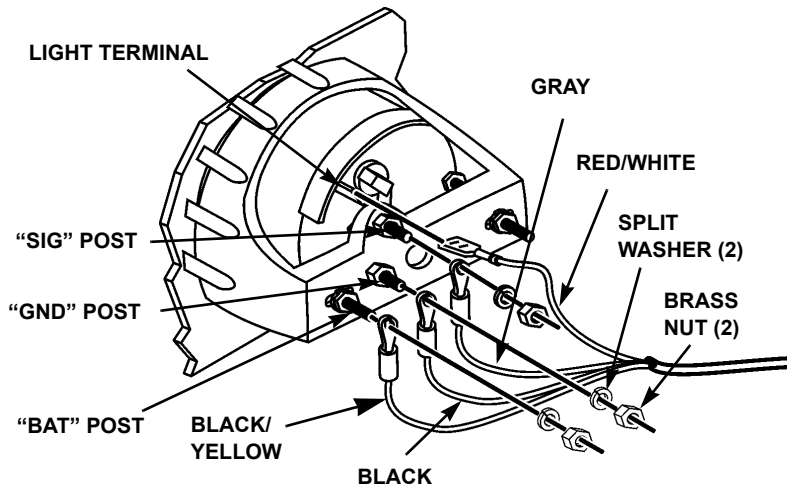

## VOLT METER

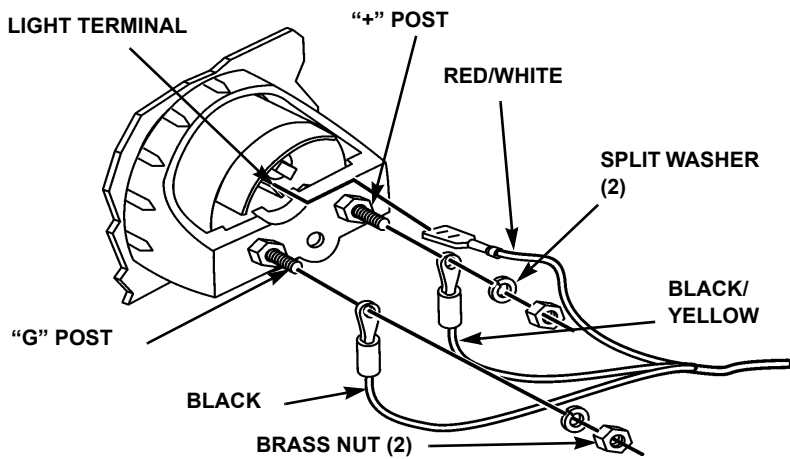

## WATER PRESSURE

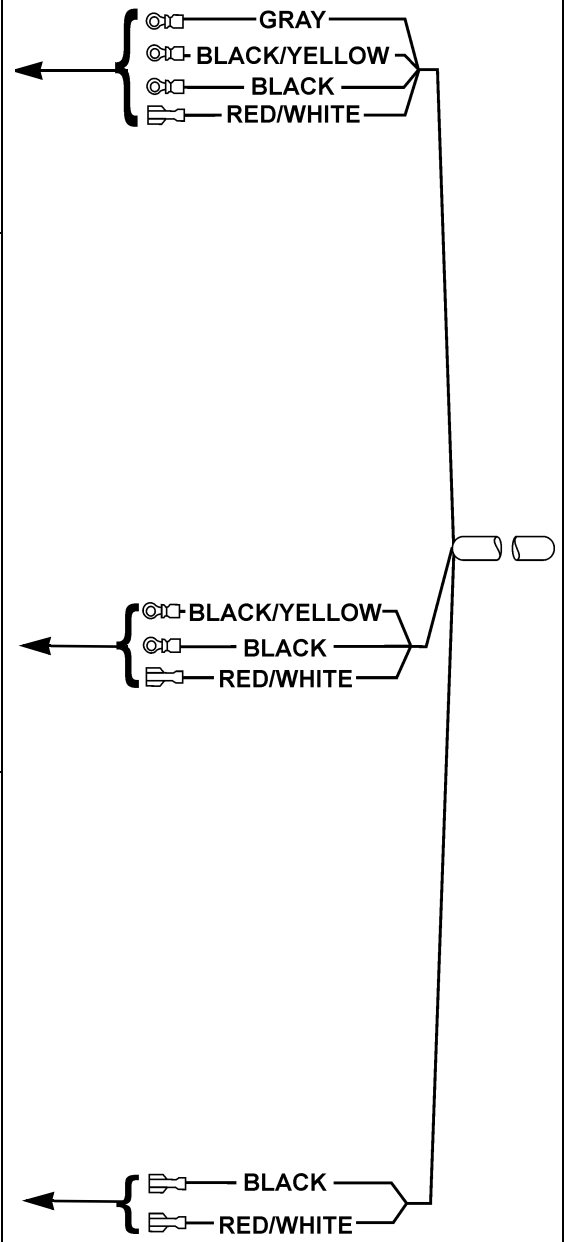
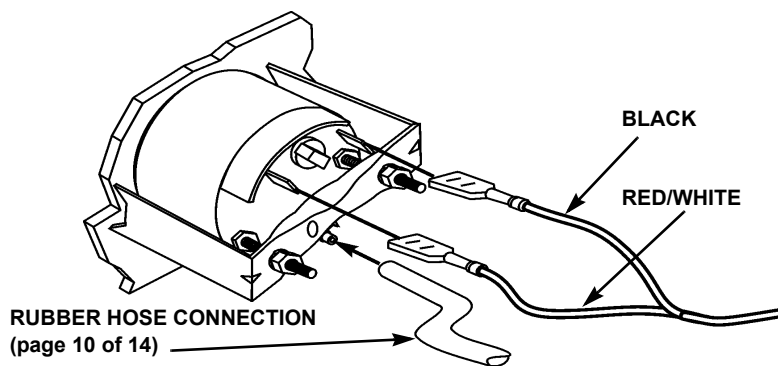

6. Connect the rubber hose for the speedometer (page 8 of 14) and water pressure gauge (page 10 of 14).
7. Before connecting the battery, recheck all electrical connections and make sure all mounting hardware is tight.
8. Reconnect the battery and check the operation of each gauge.

## HOUR METER

This hour meter will operate as long as the ignition switch is in the RUN position, and will not operate when the ignition switch is in the STOP position.

The Faria wire harness does not have connections for the Faria hour meter. If the Faria gauge set (or individual gauges), tap off any of the black/yellow wire posts with a wire and connect to the hour meter “+” terminal. Tap off any of the black wire posts with a wire and connect to the hour meter “-” terminal.

### Materials required:

- Use stranded, insulated wire not smaller than 18 AWG that is approved for marine use.
- Use insulated ¼" female spade connectors on hour meter connections.
- Use eyelet terminals to connect to the Faria gauge.

Item	Part Number	Honda Code
Female Spade Connector	07VPZ-001050A	5816574
Eyelet Terminal	07VPZ-001060A	5816582

9. Reconnect the battery and test the lighting circuit.

## SPEEDOMETER WATER TUBE

1. After installing the speedometer in the dash, connect the rubber hose to the back of the speedometer and secure with a cable tie.
2. Route the rubber hose back to the motor alongside the control cables.
  - A slight downward slope from bow to stern will help avoid trapping water.
  - Avoid sharp turns, crimping, kinking, or other forces that may reduce the inside diameter of the hose.
  - Do not coil any excess rubber hose. Carefully measure, then cut to the desired length.

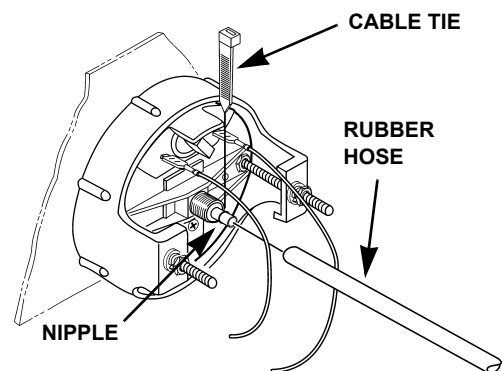
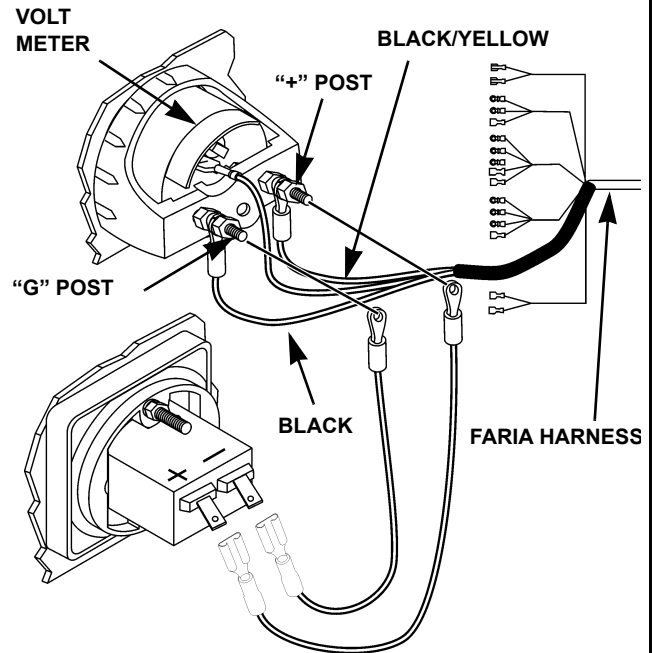



3. Fasten the rubber hose at regular intervals with small plastic wire ties (again be careful to not pinch the tubing).
4. Starting at the top of the swivel case, route the rubber hose over the top of the steering arm, down through the inside of the swivel case alongside the shift rod, and out the bottom of the swivel case to the pitot tube.

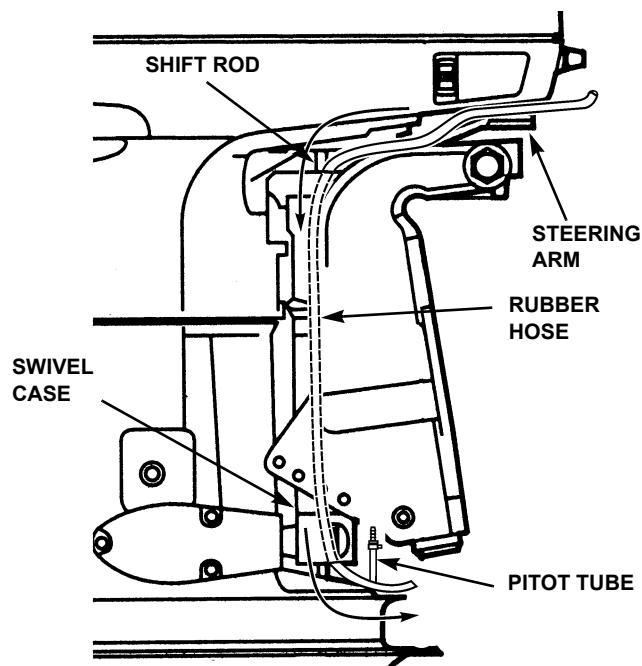

5. Cut approximately 1/8" (3 mm) off the nipple end.  
Clean the pitot tube if it is clogged with salt or any other foreign material.
6. Cut the hose to the appropriate length to reach the nipple end.
7. Press the end of the hose over the nipple and secure it with a cable tie.
8. Gently feed the pitot tube and rubber hose back up through the swivel case until a slight loop is made in the pitot tube.
9. Secure the hose to the steering arm with cable ties.

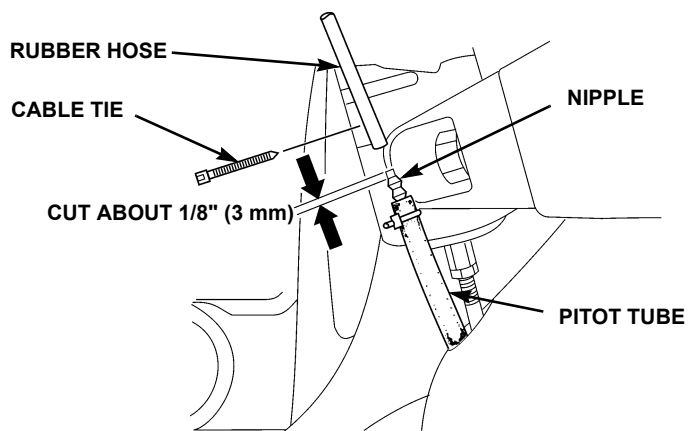

## BF135/150/200A6/225A6

1. Cut approximately 1/8" (3 mm) off the pitot tubing nipple end that extends from the rigging grommet.  
Clean the pitot tubing if it is clogged with salt or any other foreign material.
2. Cut the rubber hose to the appropriate length to reach the nipple end.
3. Press the end of the hose over the nipple and secure with a cable tie.

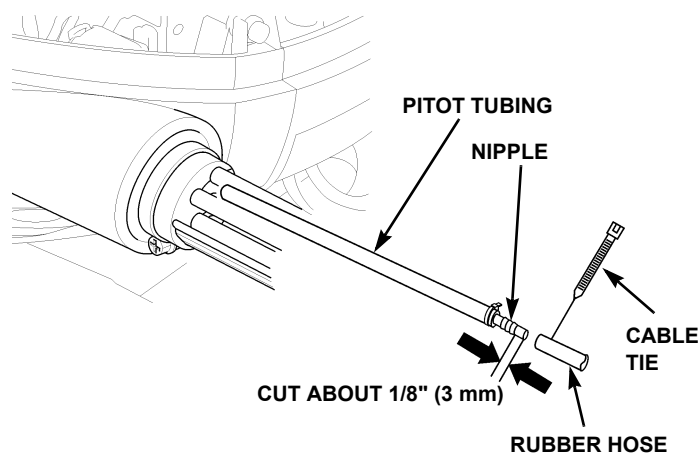

## MAINTENANCE

The pitot tube should be flushed with fresh water before storing the boat for prolonged periods. Any remaining water in the rubber hose should also be removed before storing the boat for prolonged periods.

If the pitot tube or rubber hose should become clogged:

1. Disconnect the rubber hose from the speedometer and the pitot tube.
2. Clean the rubber hose with a stiff wire or blow air through it.

### NOTICE

*Do not blow air through the rubber hose when it is connected to the speedometer. High air pressure will damage the speedometer.*

3. Flush and clean the pitot tube with fresh water. If necessary, clean the pitot tube opening with a stiff wire.
4. Reconnect the rubber hose to the speedometer and secure with a new cable tie.
5. Reconnect the rubber hose to the pitot tube nipple end and secure with a new cable tie.

## WATER PRESSURE GAUGE RUBBER HOSE

1. After installing the water pressure gauge in the dash, connect the rubber hose to the back of the water pressure gauge and secure the hose with a cable tie.
2. Route the rubber hose back to the motor alongside the control cables.
  - A slight downward slope from bow to stern will help avoid trapping water.
  - Avoid sharp turns, crimping, kinking, or other forces that may reduce the inside diameter of the hose.
  - Do not coil any excess rubber hose. Carefully measure, then cut to the desired length.

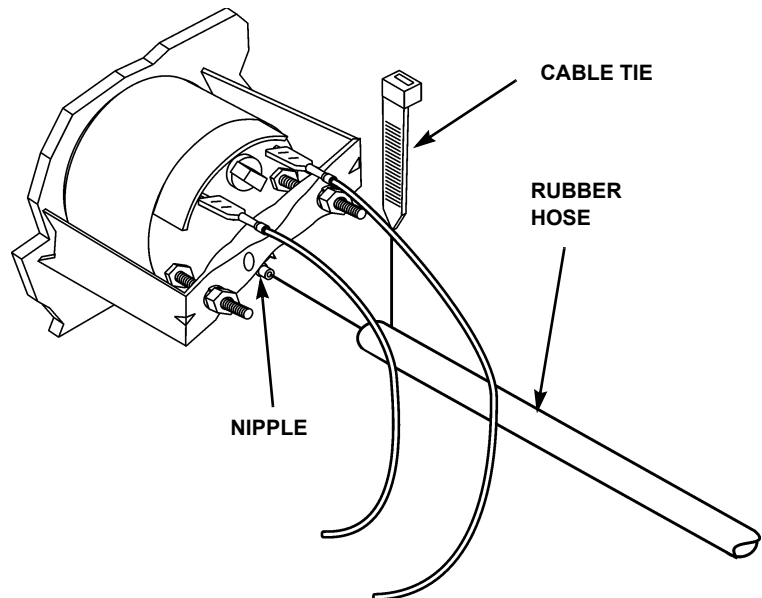

## BF75/90/115/130

1. Remove the grommet and make a hole a little larger than the rubber tubing.
2. Route the tubing through the grommet and reinstall the grommet.

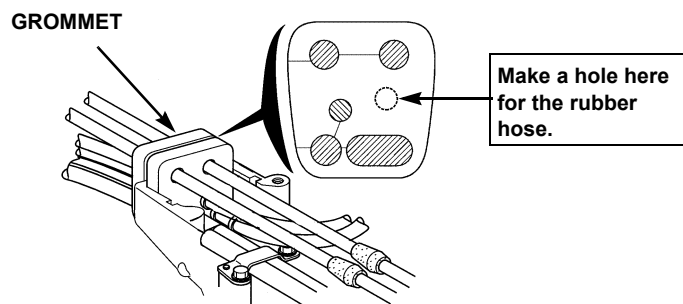

3. Remove the flush valve spacer.
4. Drill the flush valve spacer raised boss to 11/32 inch, then thread with a 1/8" NPT tap.
5. Thoroughly clean the flush valve spacer, then reinstall it.

**BF75/90**

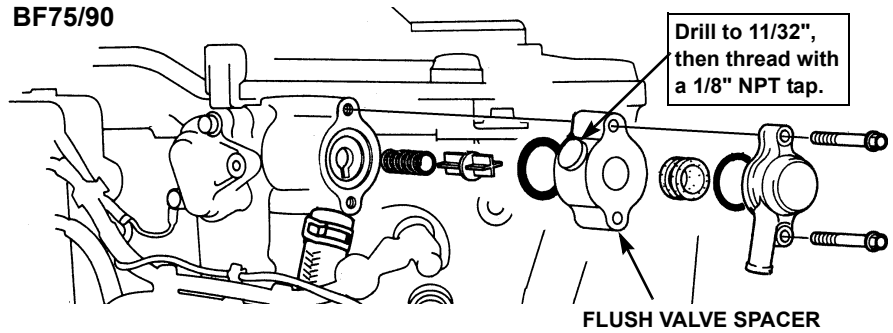

**BF115/130**

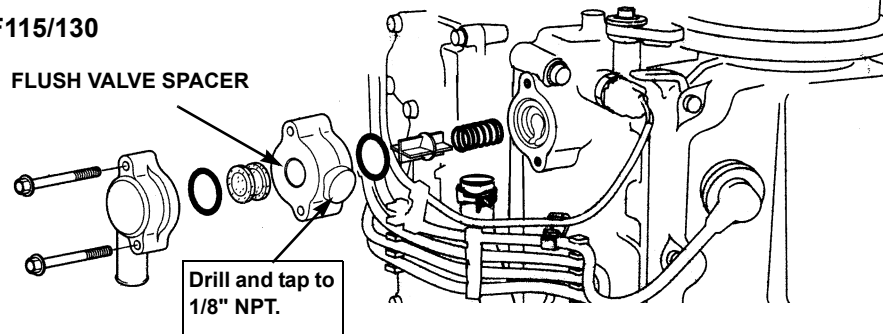

6. Apply a sealing compound to a 1/8" x 28 NPT brass hose fitting and install the fitting securely.
7. Secure the rubber tubing with a plastic cable tie.

**BF75/90**

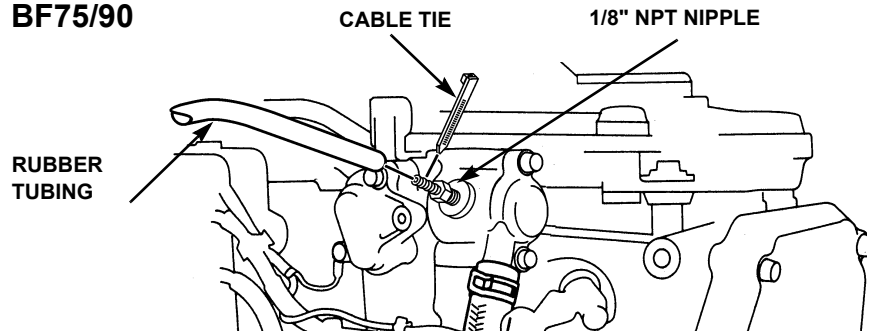

**BF115/130**

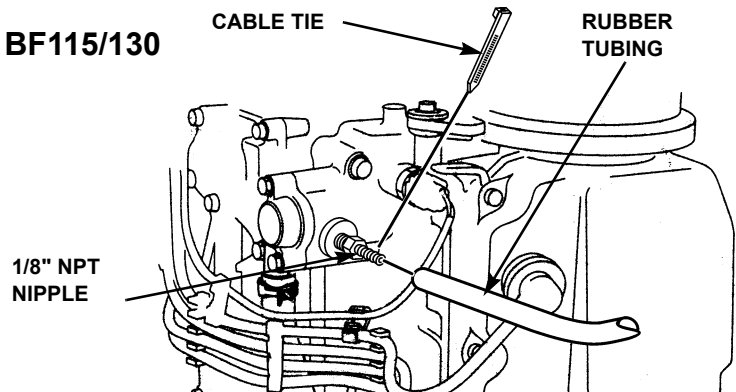

## BF135/150

1. Use a 5 mm hex wrench and remove the water pressure access plug.
2. Apply sealing compound to the 1/8" NPTF to BSPT adapter (supplied with kit) and install the adapter securely where the access plug was removed.
3. Apply sealing compound to the 1/8" NPT brass hose fitting (supplied with the kit) and install the fitting securely in the adapter.
4. Poke a small hole through the grommet membrane but don't remove the membrane. This can be done before or after the grommet is installed. A 7/32 inch drill bit can be used to open the hole.
5. Route the hose through the grommet.

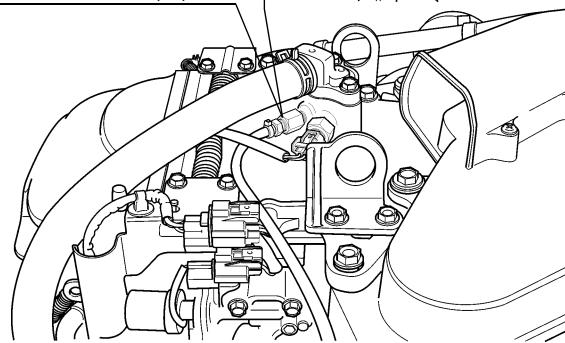
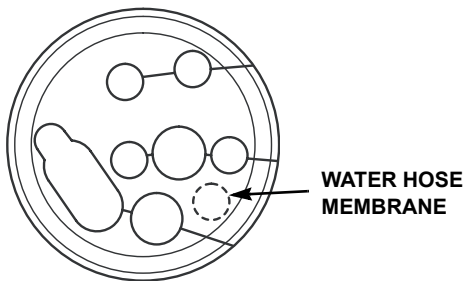
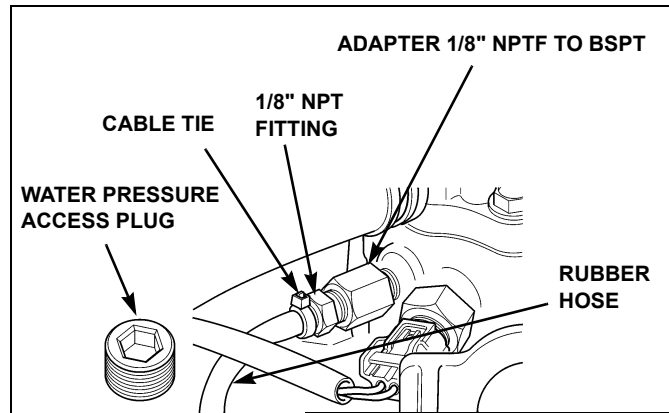

6. Secure the rubber hose to the fitting with a cable tie.

### Optional Part

A 1/8 inch BSPT brass hose barb fitting is available and can be installed in place of the 1/8" NPTF to BSPT adapter and 1/8" NPT brass hose fitting supplied with the kit.

#### 1/8 inch BSPT brass hose barb fitting:

P/N 19271-ZV5-000AH

1. Remove the water pressure access plug.
2. Apply sealant to the 1/8 inch BSPT brass hose barb fitting.
3. Install the 1/8 inch BSPT brass hose barb fitting into the engine where the water pressure access plug was removed.
4. Tighten securely.
5. Install the rubber hose to the nipple following the instructions in steps 4-6 above.

1/8" BSPT FITTING  
(P/N 19271-ZV5-000AH)

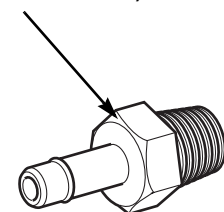

## BF200/225

1. Use a 5 mm hex wrench and remove the water pressure access plug (located above the starboard exhaust manifold).
2. Apply sealing compound to the 1/8" NPTF to BSPT adapter (supplied with kit) and install the adapter securely where the access plug was removed.
3. Apply sealing compound to the 1/8" NPT brass hose fitting (supplied with the kit) and install the fitting securely in the adapter.
4. Use a 7/32" drill bit and open the hole through the grommet membrane.

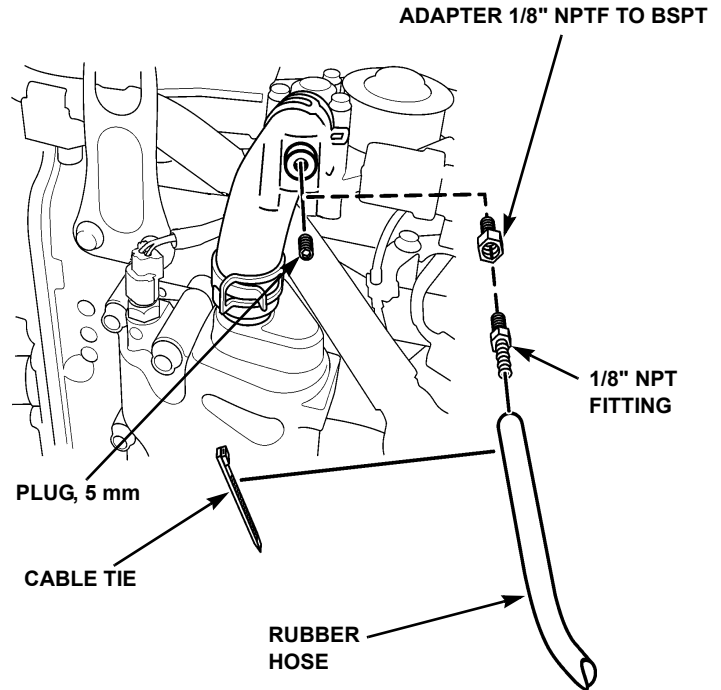
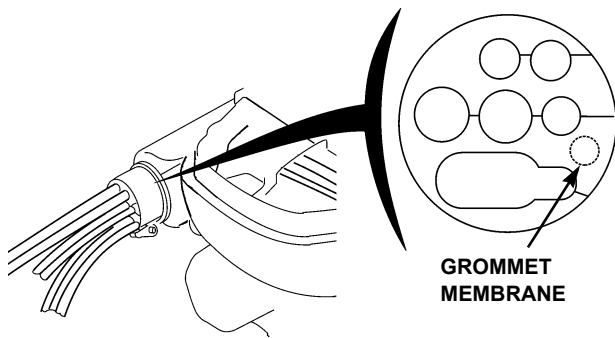

5. Route the rubber hose through the grommet hole and to the hose fitting.
6. Secure the hose to the brass fitting with a cable tie.
7. Use cable ties and secure the rubber hose to various spots on the motor, making sure the hose does not come into contact with any moving parts or hot components.

### Optional Part

A 1/8 inch BSPT brass hose barb fitting is available and can be installed in place of the 1/8" NPTF to BSPT adapter and 1/8" NPT brass hose fitting supplied with the kit.

#### 1/8 inch BSPT brass hose barb fitting:

P/N 19271-ZV5-000AH

1. Remove the water pressure access plug.
2. Apply sealant to the 1/8 inch BSPT brass hose barb fitting.
3. Install the 1/8 inch BSPT brass hose barb fitting into the engine where the water pressure access plug was removed.
4. Tighten securely.
5. Install the rubber hose to the nipple following the instructions in steps 4-7 above.

1/8" BSPT FITTING  
(P/N 19271-ZV5-000AH)

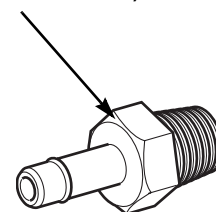

## LIGHT BULB REPLACEMENT

1. Twist the black socket assembly one-eighth turn counterclockwise and remove it.
2. Pull the bulb straight out of the assembly.

### REPLACEMENT BULBS:

GAUGE	REPLACEMENT BULB
Speedometer	GE No.158
Tachometer	GE No.1948
Fuel Gauge	GE No.194
Trim Meter	GE No.161
Volt Meter	GE No.194
Water Pressure Gauge	GE No.161
Hour Meter	NA

3. If a red lens is covering the meter bulb, remove the red lens and install it on the new bulb before reinstalling the socket assembly.
4. Reinstall the socket assembly.

